

(WE RESERVE THE RIGHT TO CHANGE DESIGN AND TECHNICAL DATA FURNISHED HERE DUE TO CONTINUOUS PRODUCT DEVELOPMENT.)

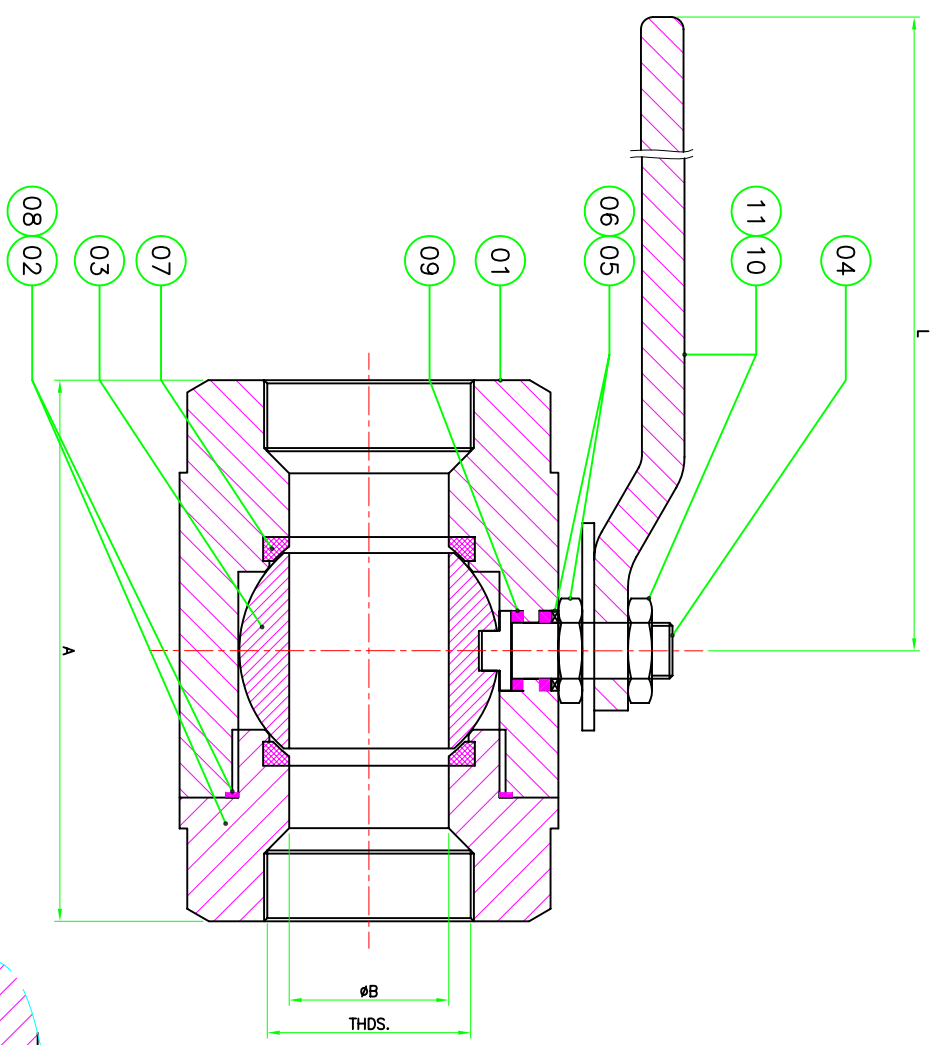

ASA 150 / 300

SIZE. NB.	A.	B.	L.	BSP/BSPPT NPT	ØF	H.
15	65	12.5	135	1/2"	21.8	15
20	75	19.0	135	3/4"	27.3	15
25	85	25.0	147	1"	34.1	15
32	92	32.0	198	1 1/4"	43.0	18
40	105	38.0	198	1 1/2"	49.0	18
50	120	50.0	198	2"	61.3	18
65	135	65.0	271	2 1/2"	77.0	18
80	150	75.0	271	3"	90.0	18
100	175	100.0	317	4"	115.2	18

SOCKET WELD END

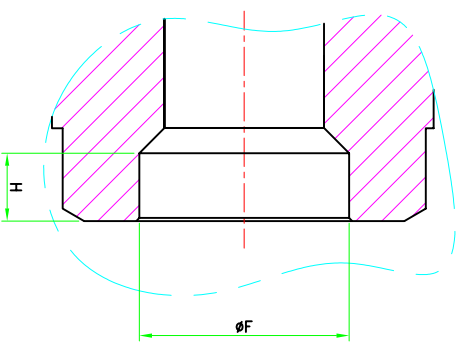

NO.	DESCRIPTION	QTY.	MATERIAL
01	BODY	01	ASTM A 216 Gr. WCB
			C.I. TO IS 210 Gr. FG 220
			ASI 304 OR CF8 (I.C.)
			ASI 316 OR CF8M (I.C.)
			ASTM A 105 (FORGED)
02	BODY CONNECTOR	01	ASTM A 216 Gr. WCB
			C.I. TO IS 210 Gr. FG 220
			ASI 304 OR CF8 (I.C.)
			ASI 316 OR CF8M (I.C.)
			ASTM A 105 (FORGED)
03	BALL	01	ASI 304/ASI 316
04	STEM	01	ASI 304/ASI 316
05	GLAND NUT	01	ASI 304/ASI 316
06	GLAND BUSH	01	ASI 304/ASI 316
07	SEAT RING	02	PTFE OR FILLED PTFE
08	BODY SEAL	02	PTFE OR FILLED PTFE
09	STEAM SEAL	02	PTFE OR FILLED PTFE
10	LOCK NUT	01	ASI 304/ASI 316
11	LEVER	01	C.S./M.S./S.S.304/S.S.316

TECHNICAL DATA

MFG. STD. :- BS 5351, API 602
 INSP. STD. :- API 598/BS5146/BS 6755 PART-1
 END TO END :- ASME B 16.10
 ENDS : SCREWED : (BSP/BSPPT,NPT)
 SOCKET WELD : ANSI B 16.11/ANSI B 2.1

PRESSURE TEST (HYDRAULIC):-

150#	BODY :- 32 KG/CM2 (g) SEAT :- 22 KG/CM2 (g)	300#	BODY :- 80 KG/CM2 (g) SEAT :- 58 KG/CM2 (g)
------	--	------	--

UNSPECIFIED TOLERANCE FOR MACHINED DIM.	DESCRIPTION
0-75 ± 0.2	ASLY OF SINGLE PIECE BALL VALVE
75-300 ± 0.4	
300-600 ± 0.6	
600-1000 ± 0.75	
RATING	SIZE
150,300#	15 TO 100 (mm)
END CONNECTION	STANDARD
SCREW ENDS	BS 5351

ALL DIMENSIONS ARE IN M.M. UNLESS OTHERWISE SPECIFIED REMOVE SHARP CORNERS

MANUFACTURERS & EXPORTER
M. KUMAR TECHNOCRATES
 SR/9,PAMBHA COMPLEX, ASHRAM ROAD,
 AHMEDABAD - 380 014,(GUJARAT) INDIA
 Phone:-0091-79-27540287.
 Fax:-0091-79-27545519.
 E-mail:-info@tritechnives.com
 Website:-trtp/ www.dtritechnives.com

SCALE	N.T.S.	GHV	AS STATED
VALVE TYPE			
BALL VALVE			
PROJECTION			
THIRD ANGLE			
SHEET No.	01	OF	01
DRW. No.			
REV.			